

# LEISURETIME II™

Fibreglass sand filter



## SO CLEAN. SO CLEAR. SO EASY.

The Leisuretime II Fibreglass Sand Filter is the perfect high performance sand filter. It's incredibly simple to operate and maintain, and it's built with long-term reliability in mind. Plus, its highly efficient design provides all the clean, crystal clear water your pool requires year after year. Here's how.

Pool water is routed through the sand-filled pressure vessel. The sand traps particles so small they are undetectable to the naked eye. Over time, dirt accumulates in the spaces between the sand particles, causing the pressure in the vessel to rise. This signals you to "backwash" the filter. Simply reverse the water flow and "knock out" the dirt.

Pool filter operation doesn't come any easier. The multi-port valve puts all filter functions right at your fingertips—just rotate the handle to the desired position and the Leisuretime filter does the rest for sure and simple operation.

## FEATURES & BENEFITS

- Spun-woven fibreglass construction for exceptional strength, chemical resistance and long life.
- UV resistant tank.
- Stainless Steel clamp for corrosion resistance and allows 360 degree rotation of multi-port valve to simplify installation.
- Top diffuser ensures even distribution of water over the top of the sand bed.
- Top Mount 6-function 1-1/2" multi-port valve features a pressure gauge, sight glass and manual air relief for optimum filtration efficiency. Large capacity 25" and 28" models are available with a 2" valve.
- Internal design ensures that water is exposed to maximum sand surface area for superior filtration performance and efficient backwashing.



*The Leisuretime II sand filter does to your pool what the coral does to the ocean. "It Keeps it clean."*

# LEISURETIME II™

Fibreglass sand filter

Spun-woven, UV resistant fibreglass construction for exceptional strength, chemical resistance and long life.

Six-function multi-port valve for easy control of all filter functions  
 • Filter • Waste • Backwash • Closed • Rinse • Re-circulate

Stainless Steel clamp for corrosion resistance and allows 360 degree rotation of multi-port valve to simplify installation.



## MATERIALS

Component	Material
Filter Body	Fibreglass, spun woven.
Filter Internal Liner	HDPE
Base	PP
Clamp	Stainless steel 304
Laterals	Hi-Strength PVC/ABS Composite
Hub	Hi-Strength PVC/ABS Composite
Stem Pipe	PVC
Multi-Port valve	ABS
MPV Body	ABS
MPV Rotor	ABS
MPV Handle	ABS
MPV Gasket	TPE
MPV O-Rings	NBR
Barrel Unions	ABS
Pressure Gauge	Oil-Filled, Stainless Steel, 1/4" BSPT, 0-250kPa

## FILTER HEAD LOSS CURVE

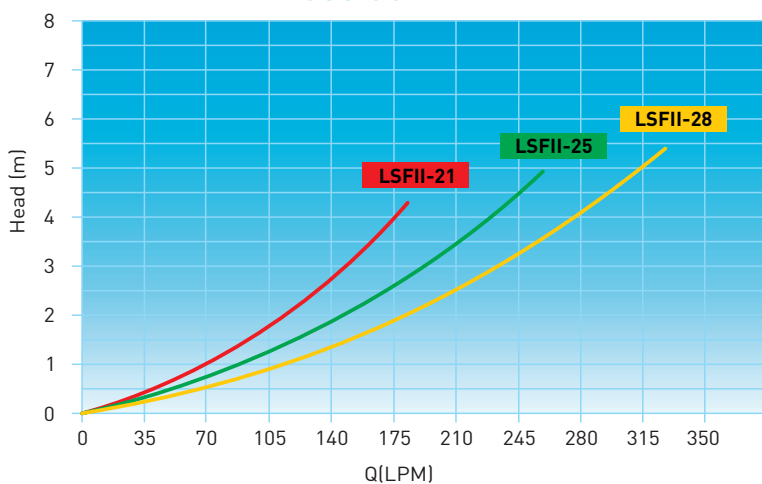

## FILTER DATA

Filter Model	Filter area	MPV	Sand Weight	Max.Flow	Min.Backwash
LSFII-21-40	0.20m <sup>2</sup>	1.5"/40mm	90kg	190lpm	120lpm
LSFII-25-40	0.30m <sup>2</sup>	1.5"/40mm	160kg	260lpm	180lpm
LSFII-25-50	0.30m <sup>2</sup>	2.0"/50mm	160kg	280lpm	180lpm
LSFII-28-50	0.38m <sup>2</sup>	2.0"/50mm	200kg	350lpm	230lpm

## DIMENSION TABLE

Dimension A	Dimension B
875	535
980	635
985	635
1050	723

## OPERATING CONDITIONS

Maximum working pressure	250kPa
Maximum working temperature	50°C
Maximum water temperature	43°C
Size of silica sand	0.5 - 0.8mm



AVAILABLE FROM:



### Head Office

Pentair AU/NZ:

1-21 Monash Drive,  
Dandenong South, Vic 3175

### New Zealand

National Customer Service: Phone: 0800 654 112

Fax: 0800 806 642

National Dealer Locator: Phone: 0800 664 269

Email: nz.sales@pentair.com

Web: www.pentair.co.nz

### Australia

National Customer Service: Phone: 1300 137 344

Fax: 1800 006 688

National Dealer Locator: Phone: 1800 664 266

Email: au.sales@pentair.com

Web: www.pentair.com.au

### International Australia/New Zealand

Phone: +61 3 9709 5800

Fax: +61 3 9709 5888

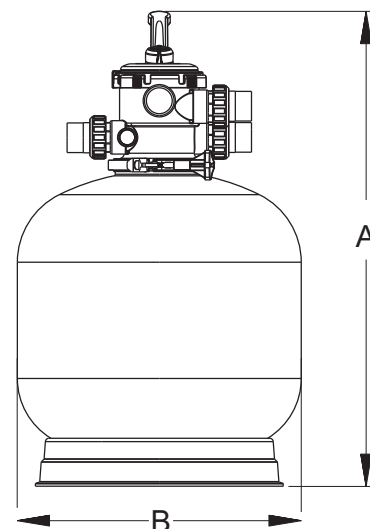

pumps / filters / heaters / heat pumps / automation / lighting / cleaners / sanitizers / water features / maintenance products

©2013 Pentair Aquatic Systems. All rights reserved.

Display, publication, modification or distribution is strictly prohibited without the prior written permission of Pentair Water Pty Ltd.  
**Disclaimer:** Every endeavour has been made to publish the correct details in this publication. No responsibility will be taken for errors, omissions or changes in product specifications. Pentair reserves the right to change specifications.

L300219 0413