

OWNERS MANUAL



onga
Pentair Water



For the Installation, Operation and Service of the

ECO800™

Variable Speed Pool Pump



Should the installer or owner be unfamiliar with the correct installation or operation of this type of equipment you should contact the distributor/manufacturer for the correct advice before proceeding with the installation or operation of this product. The pump operator or owner must be provided with this owner's manual.

Onga and Pentair

Onga has been servicing the Australian and New Zealand markets with the highest quality water movement products for just over 40 years. Established in 1967, Onga has a product to meet your every water need.

Onga is part of the Pentair group, a global leader in swimming pool, spa and aquatic equipment. The business has built a reputation as an innovation leader, providing high performance, reliable and energy-efficient filters, controls, sanitizers, pumps, heaters, cleaners, and accessories for residential and commercial pool owners and operators.



Eco Select®

The Eco Select® brand identifies our most eco-friendly products

As the global leader in pool and spa equipment, we've made a strong commitment to develop and offer the most environmentally responsible products available.

When you see the Eco Select® brand on one of our products, you'll know it is our "greenest" and most efficient product in that equipment category.

These products do the best job of saving energy, conserving water, reducing noise, or otherwise contributing to a more environmentally responsible equipment system. In every case, a product that earns the Eco Select brand is clearly our "greenest" and most efficient choice.



	Page
▶ Features and Benefits	3
<hr/>	
▶ Technical Information	
Model Data	4
Hydraulic Performance	5
Dimensions	5
<hr/>	
▶ Installation	
Pump Positioning	6
Piping	6
Pool Outlets	7
Electrical	7
Equipotential Bonding	7
<hr/>	
▶ Operation	
Priming the Pump	8
Speed Selection	9
Variable Speed Adjustment	9
<hr/>	
▶ Service & Maintenance	10
<hr/>	
▶ Troubleshooting	
Troubleshooting Guide	11,12
Motor Flash Codes	13
<hr/>	
▶ Spare Parts	14



The Onga Eco800 is the ideal pump for new or existing pools. Utilising advanced hydraulic design and the latest technology in permanent magnet, variable speed motors, the Onga Eco800 has the perfect combination of efficiency and performance. The Onga Eco800 delivers energy savings and the power when you need it. You will also have the peace of mind that you are doing your bit for the environment and reducing your carbon foot print.

- ▶ Variable speed pump, with 3 programmable speeds, allows you to effortlessly select the most efficient setting to meet your filtration, cleaning and water feature needs.
- ▶ Axial flux, brushless permanent magnet motor delivers high efficiency and low noise levels.
- ▶ Fault protected motor prevents damage by automatically shutting down the motor in the event of a locked rotor, under voltage, over voltage or over current condition and will automatically reduce the speed during an over temperature condition.
- ▶ Precision-fit internal components and superior hydraulic design deliver effortless performance, energy savings and extended pump life.
- ▶ A specially designed sound-dampening pump casing and base make pump operation incredibly quiet.
- ▶ Constructed of our durable, thermoplastic, composite resin, so you can be sure it will stand up to the harshest conditions.
- ▶ A heavy-duty construction and a motor rated for continuous operation make the Eco800 a tough, long-lasting performer.
- ▶ The high-capacity trap holds a large amount of debris, so you clean less often.
- ▶ The Cam and Ramp™ lid is easy to remove and locks in place with a quarter turn, making inspection and cleaning a breeze.
- ▶ Quick-disconnect plumbing unions.



Model:

ECO800

RPM:
 Low 1450RPM (default factory setting)
 Med 2400RPM (default factory setting)
 High 2800RPM (default factory setting)
 Adjustable Range: 1000-2850RPM

Electrical Rating: 230-240V 50Hz single phase

Rated Current:
 Low: 1.3A (max)
 Med: 4.4A (max)
 High: 6.5A (max)

Input Power (P1):
 Low: 160W (max)
 Med: 595W (max)
 High: 940W (max)

Pump Power (P2):
 Low: 130W (max)
 Med: 475W (max)
 High: 750W (max)

Maximum Ratings: 2850RPM, P1 975W, P2 800W, 6.7A

IP Rating: IP25

Inlet (Suction): ABS Barrel Union to suit 50mm PVC pressure pipe to AS/NZS 1477

Outlet (Discharge): ABS Barrel Union to suit 50mm PVC pressure pipe to AS/NZS 1477

Max Working Pressure: 260 kPa

Water Temperature Range: 5°C - 40°C

Maximum Ambient temperature: 55°C

Recommended pH Range: 7.2 - 7.8 (Guide Only)

Sound Power Level (Lwa):
 Low: 57.5dB
 Med: 65.2dB
 High: 69.3dB

Motor: Axial flux, permanent magnet, DC

Protection: Mains over voltage, mains under voltage, over temperature, under temperature, locked rotor, over current, phase disconnect.

Supply cord: 10A, H07RNF, 2m.

Hydraulic Performance

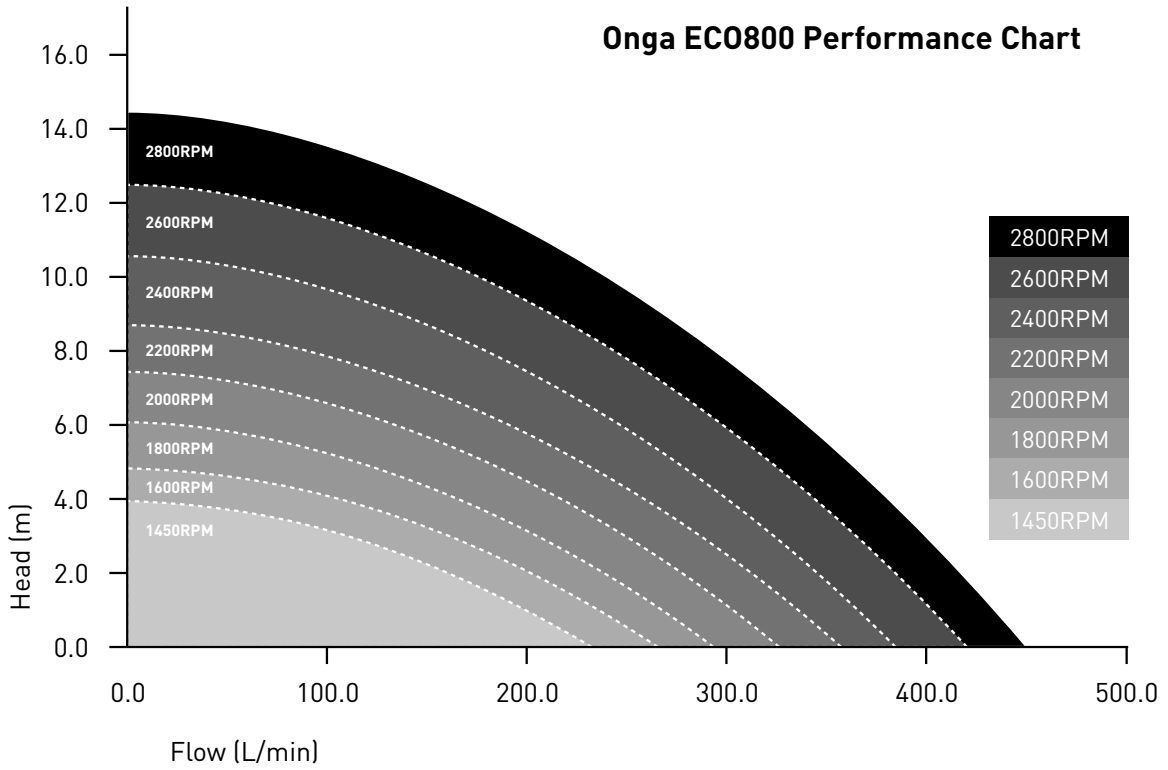

Dimensions

A	637mm
B	179mm
C	256mm
D	354mm

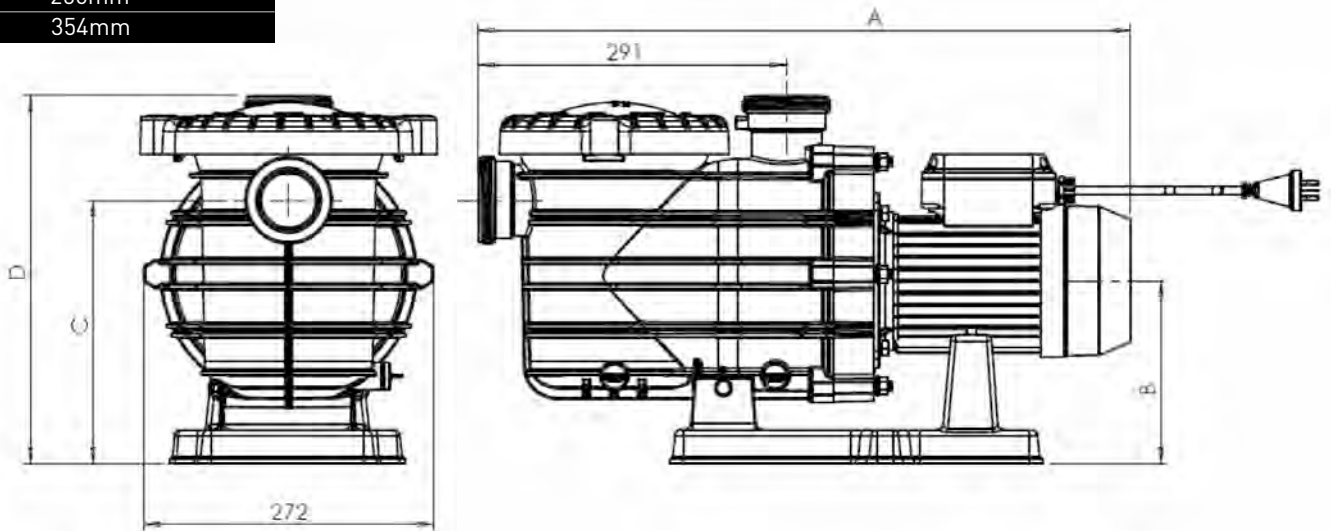



The pump must be installed and serviced by a suitably qualified person in order to avoid hazard. Incorrectly installed or tested equipment may fail, causing severe injury or property damage.



These instructions are a guide only. Should you the installer or owner of the product be unfamiliar with the correct installation or operation of this product you should contact a suitably qualified person for advice.



Do not connect system to high pressure or mains water system.



This pump is not intended for use by persons (including children) with reduced physical, sensory or mental capabilities, or lack of experience and knowledge, unless they have been given supervision or instruction concerning use of the appliance by a person responsible for their safety.



Children should be supervised to ensure that they do not play with the pump.



The Eco800 is electrically connected. Ensure that it is isolated from electrical supply during installation and any subsequent service work.

1. Plan the position of the pump



For best performance, allow pump suction inlet height to be as far below water level as possible and allow the use of short, direct suction pipe with minimum bends (to reduce friction losses).

- a) Have enough ventilation to keep ambient temperature below the motor's rated ambient temperature whenever the pump is running. If installed in an enclosure/pump house, the enclosure must have adequate ventilation (200sq.cm min, inlet & outlet) and air circulation Allow 200mm to keep rear of motor clear.
- b) Have adequate floor drainage to prevent flooding and be protected from excess moisture.
- c) Be solid, level, rigid and vibration free.
- d) To reduce vibration and pipe stress, bolt pump to mount. Fixing holes accept 12mm fasteners.
- e) Be within 2m of a power outlet for electrical connection (refer to AS/NZS 3000 for rules regarding connection of electrical equipment in pool zones).
- f) Allow adequate access for servicing pump and piping.

2. Piping



For best performance, allow pump suction inlet height to be as far below water level as possible and allow the use of short, direct suction pipe with minimum bends (to reduce friction losses).

- a) Use only Australian Standard PVC pressure pipe. For best performance use at least 50mm diameter pipe for all connections to the pump. Never use a suction pipe smaller than pump suction connections (50mm) and use larger pipe for long suction distances.
- b) To avoid stress on the pump, support both suction and discharge pipes independently. Place these supports as close to the pump as possible.
- c) To avoid a strain left by a gap at the last connection, start all piping at the pump and run pipe away from the pump.

3. Pool Outlets



- a) The pump suction system must provide protection against hazard of suction entrapment or hair entrapment/entanglement. The pool outlet piping must be in accordance with the latest AS1926.3 standard
- b) Suction outlet covers and skimmers must have been tested and found to comply with the latest AS1926.3 standard or ASME/ANSI specification for Suction Fittings.

4. Electrical

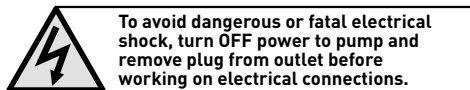
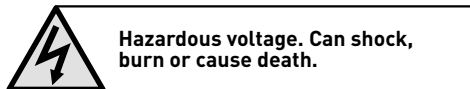
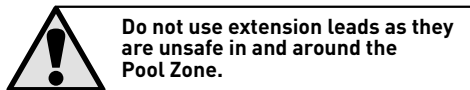

- a) Electrical installation shall be in accordance with the national wiring rules (AS/NZS 3000) taking into account its ratings (Class I, IPX5). The pump is supplied with a standard Australian 10 amp plug and 2 metres of cord. Select the correct Pool Zone for installation.
- b) An RCD with maximum rated residual current of 30mA is required for the power supply to the pump. Additionally, if a suitable socket outlet is not available a weatherproof socket must be installed by an electrician in a suitable location. RCD tripping indicates an electrical problem. If RCD trips and will not reset have a qualified electrician inspect and repair electrical system.
- c) Incorrect voltage can cause fire or seriously damage pump and voids warranty.
- d) Voltage at pump must not be more than 6% above or 10% below motor nameplate rated voltage or pump may overheat, causing overload tripping and reduced component life. If voltage is less than 90% or more than 106% of rated voltage when pump is running at full load, consult the power company.

5. Equipotential bonding

If equipotential bonding is required (refer to local statutes and regulations), connect all metal parts of the swimming pool or spa structure and to all electrical equipment, metal conduit, and metal piping in accordance with the wiring rules. Run a wire from the equipotential bonding terminal on the pump (bottom, left motor bolt with serrated washer) to the pool bonding structure.



NEVER run pump dry. Running pump dry may damage seals, causing leakage and flooding. Fill pump with water before starting motor.



Freezing conditions will damage the unit, as water expands as it freezes. Ensure that the Eco800 is located so that it is not prone to freezing, or ensure that the product is disconnected and dried of water during cold conditions.



Trapped air in system can cause explosion. Ensure all air is out of the system before operating or testing equipment



Fire and burn hazard. Modern motors run at high temperatures. To reduce the risk of fire, do not allow leaves, debris, or foreign matter to collect around the pump motor. To avoid burns when handling the motor, let it cool for at least 20 minutes before trying to work on it.



Small children using pool must ALWAYS have close adult supervision



Pump suction is hazardous and can trap and drown or disembowel bathers. Do not use or operate pump, pool/spas if a suction outlet cover is missing, broken, or loose. Follow the guidelines below for a pump installation which minimises risk to users of pool and spas.



NEVER tighten or loosen trap lid while pump is operating.

1. Priming the pump



It is not necessary to lubricate the o-ring. The original equipment O-ring contains a permanent internal lubricant.

- a) Before removing trap lid, SWITCH OFF POWER SUPPLY to pump.
- b) CLOSE SHUT-OFF VALVES on suction and discharge pipes, if present.
- c) Remove the trap lid (turn anti-clockwise)
- d) Fill trap tank with water.
- e) Check the lid o-ring and sealing surface, ensure there is no dust or debris on either, and replace the lid (turn clockwise to tighten by hand only - no wrenches!).
- f) Open the shut-off valves on the suction and discharge pipes, if present.
- g) Release all air from filter, pump and piping system (refer filter owner's manual). In a flooded suction system (water source higher than pump), pump will prime itself when suction and discharge valves are opened and air is released.
- h) Switch on power to the pump to start.
- i) Pump should start to prime now. Priming time will depend on vertical height of suction lift and horizontal length of suction piping but is generally between 30 seconds to 3 minutes under normal installation conditions.
- j) The Eco 800 will start slowly but ramp up to high speed for the first 2 minutes to assist priming. It will then switch to the selected speed.

*** Should the pump not prime, ensure that all valves are open, lint trap is clear of debris and suction pipe end is submerged in water, and that there are no leaks in suction pipe. See troubleshooting guide.**



2. Speed selection

The Onga Eco800 comes pre-programmed with the following default speeds:

	Press for low speed	Press for medium speed	Press for high speed
	<p>1450RPM</p> <p>Low</p>	<p>2400RPM</p> <p>Med</p>	<p>2800RPM</p> <p>High</p>
	<ul style="list-style-type: none"> Filtration and water circulation 	<ul style="list-style-type: none"> Cleaning with a suction cleaner 	<ul style="list-style-type: none"> Backwashing filter. Operating some water features such as jets or waterfalls. Solar heating
Speed / Application			



Off button

Press to turn power on/off.

If power is removed, motor will return to the last speed selected when power is restored. Motor will remember ON/OFF state.

3. Variable Speed Adjustment

If the default speed settings do not perfectly match the particular installation. They can be adjusted as follows.

1.	, or	Press and hold button corresponding to speed you wish to change. Hold for 3 seconds and a light should begin to flash.
2.		To decrease speed by 50rpm increments with 1000rpm as the minimum limit
		To increase speed by 50rpm increments with 2850rpm as the maximum limit
3.		To save the current speed setting and return to normal operation mode
		Will cancel the change and revert back to the original speed and return to normal operation mode
	+ +	Holding all 3 buttons for 3 seconds will reset the speeds to default

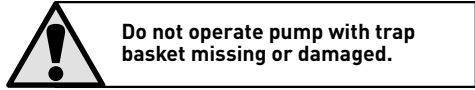
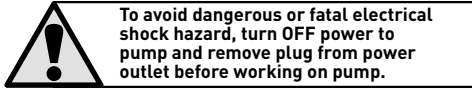

► It is essential for the longevity of the pump that regular service and maintenance be carried out. The Onga Eco800 incorporates high velocity moving parts and is pumping water containing harsh pool chemicals. Some parts which will wear during the normal operation and expected life of the pump.

FREQUENCY

Once per week

Once per month

CHECK

✓ Inspect trap basket, and empty of any leaves and other debris. Leaves and other debris that collects in basket will choke off water flow through the pump and reduce efficiency and performance. See below instructions on cleaning the trap.

✓ Check the pump to ensure no water is leaking from inlet and outlet joints, whilst pump is operating. If leaks are noticed, clean and grease the o-rings or replace if necessary.

✓ Clean area around pump and ensure there are no leaves or debris which could become a fire hazard or choke the motor fan.

✓ Check that there are no leaks from under the pump. If there are, this could be a sign of a leaking mechanical seal. Call a Pentair Service Agent immediately, to prevent damage to the motor.

✓ Check pump and motor for insects and pest infestations and ensure that motor fins are clean of dust and dirt. Clean if necessary.

Follow instructions below to clean trap:

1. Switch off power to pump, close valves in suction and discharge, and release all pressure from system before proceeding.
2. Remove trap cover (turn counter clockwise). If necessary, tap handles gently with a rubber mallet.
3. Remove strainer basket and clean. Ensure all holes in basket are clear, flush basket with water and replace in trap with large opening at pipe connection port (between ribs provided). If basket is replaced backwards, the cover will not fit on trap body.
To clean transparent cover, use water and neutral soap only. Do not use solvents.
4. Clean and inspect lid o-ring; reinstall on trap. Clean O-ring groove on trap body and replace cover. To help keep cover from sticking, tighten hand tight only.
5. Prime pump (refer priming instructions).



The Onga Eco800 should only be serviced by certified Pentair service agents. For best results and to ensure warranty is not void, insist on use of only genuine Pentair service parts.



To avoid dangerous or fatal electrical shock hazard, turn OFF power to pump and remove plug from power outlet before working on pump.



The power supply cord has a type 'Y' attachment and if service is required to the power cord, it must be replaced with the specialised power cord assembly by Pentair Water service agent or similarly qualified personnel in order to avoid a hazard. Warranty is void if unauthorised modifications are made to any component.

► TROUBLESHOOTING GUIDE

SYMPTOM	CAUSE	REMEDY
<p>Low water pressure, low flow from pump.</p>	<p>Suction leaks / lost prime.</p>	<ul style="list-style-type: none"> ▶ Pump must be primed; make sure that the pump casing and strainer are full of water. Refer priming instructions. ▶ Make sure there are no leaks in suction piping and ensure all o-rings are present and clean. ▶ Make sure suction pipe inlet is well below the water level to prevent pump from sucking air. ▶ Suction lift of 3 to 6 metres will reduce performance. Suction lift of more than 6 metres will prevent pumping and cause pump to lose prime. In either instance, move the pump closer (vertically) to water source. Ensure that the suction pipe diameter is large enough.
	<p>Low speed setting.</p>	<ul style="list-style-type: none"> ▶ Check speed setting. Refer to speed selection section of this manual. Reset to default if necessary.
	<p>Clogged pipe / strainer / impeller / filter system.</p>	<ul style="list-style-type: none"> ▶ Ensure trap is not clogged with debris; clean basket and/or filter. ▶ Make sure that the impeller is not clogged. This should be checked by qualified personnel only. ▶ Pump may be trying to push too high a column of water. If so, a higher pressure pump is required.



► TROUBLESHOOTING GUIDE (continued)

SYMPTOM	CAUSE	REMEDY
<p>No water coming from pump (pump is working).</p>	<p>Air ingress to system.</p>	<p>► Prime the pump. Check that there are no air leaks in the suction piping or fittings. Ensure the strainer lid is airtight and fitted securely. Ensure all o-rings are present.</p>
<p>Pump does not work.</p>	<p>Motor fault.</p>	<p>► Refer to motor fault codes.</p>
	<p>No power at outlet.</p>	<p>► Use another electrical appliance that is known to work to check power outlet.</p>
	<p>Blown fuse / Circuit breaker.</p>	<p>► Check and call electrician if necessary.</p>
<p>Pump running too slow.</p>	<p>Low speed setting.</p>	<p>► Check speed setting. Refer to speed selection section of this manual. Reset to default if necessary.</p>
	<p>Motor high temperature limit exceeded.</p>	<p>► Ensure motor fins are clean and fan is intact and free from blockages. Ensure adequate ventilation and reduce ambient temperature.</p>
<p>Water leaking from between the casing and motor.</p>	<p>Casing bolts are not tightened sufficiently; worn mechanical seal requires replacing.</p>	<p>► Switch off the power to the pump. Tighten the casing bolts or replace the mechanical seal as required.</p>

Should problems persist, contact your nearest Pentair Water Service Agent.



The variable speed motor is a sophisticated and highly technical device. Should a fault occur with the motor, it cannot be serviced and must be replaced by a certified Pentair service agent, service agent or similarly qualified personnel in order to avoid a hazard. Warranty is void if unauthorised modifications are made to any component.

- ▶ If a fault develops with the motor, the error light will flash a number of times as per the following table. Faults can be cleared by resetting power to the motor. If faults persist contact your Pentair service agent.

▶ **MOTOR FLASH CODES**

No. of flashes							
1	2	3	4	5	6	7	8
Microcontroller failure	Mains under voltage	Over Temperature	Over Current	Mains over voltage	Output shaft seized	Self check failed	Motor fault
Microcontroller is continually rebooting.	The mains voltage has dropped below 180VAC.	Motor temperature has exceeded maximum limit. Speed will reduce until motor returns to acceptable temperature.	Over current protection has tripped. Speed will reduce until motor returns to acceptable condition.	The mains voltage has risen to above 269VAC	Motor shaft seized due to blockage in pump or fan.	One or more of the self-tests failed during start up or while running.	One or more of the phases has become disconnected.

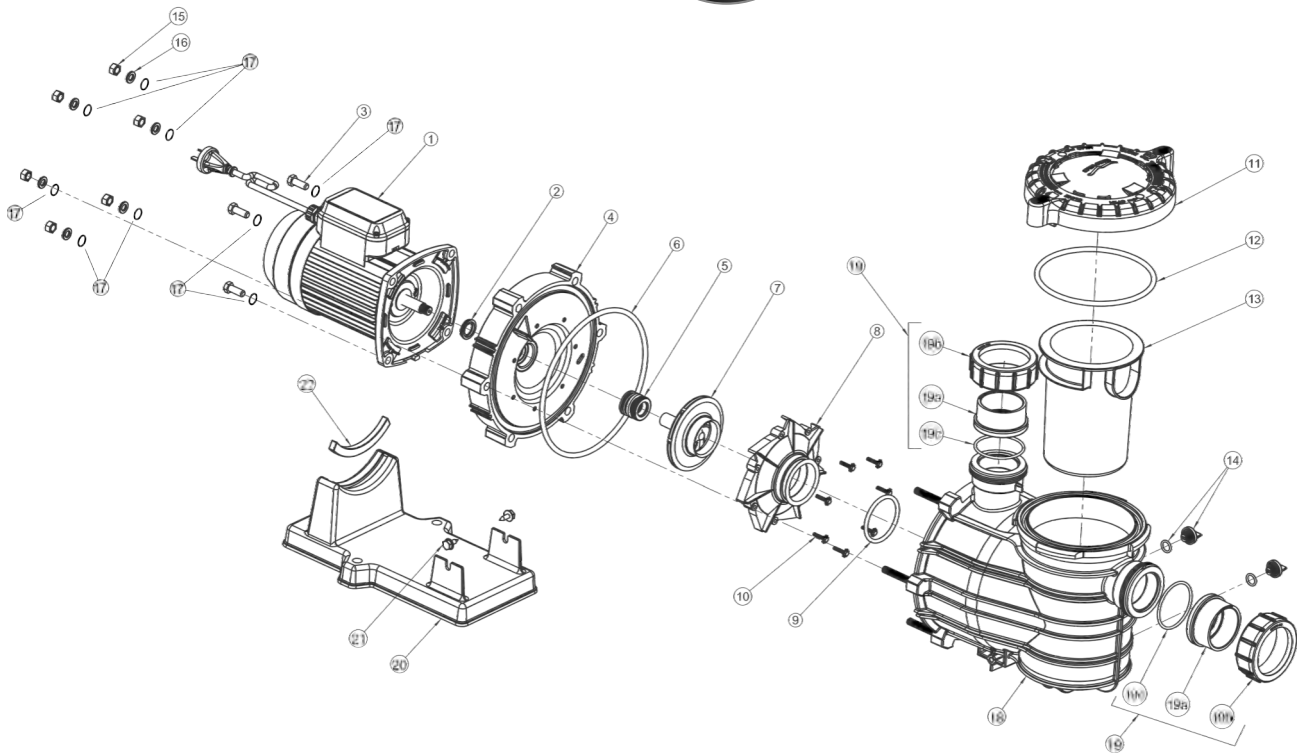

No.	Description	Qty	Part Number
EC0800			
			801301
1	MOTOR	1	(405695)
2	SLINGER	1	See Motor
3	SCREW 3/8"UNC x 1" HEX SS	4	See Motor Fasteners Kit
	MOTOR FASTENERS KIT (INCLUDES ITEM 3x4)	1	801279
4	SEAL PLATE	1	C3-184P
5	MECHANICAL SEAL	1	801428
	MECHANICAL SEAL (25 PACK)		800900
6	O-RING PUMP CASING	1	1660500
7	IMPELLER	1	801426
8	DIFFUSER	1	
9	O-RING DIFFUSER	1	See Diffuser and O-Ring Kit
10	SCREW 8/32" x 22mm SS PHILLIPS HEAD	7	
	DIFFUSER & O-RING KIT (INCLUDES ITEM 8, 9 & 10x7)	1	801423
11	LID	1	17307-0111
12	O-RING LID	1	35505-1440
13	BASKET	1	C8-58P
14	DRAIN PLUG & O-RING	2	U178-920P
15	NUT 3/8" SS	6	
16	WASHER SPRING M10 SS	6	See Pump Fasteners Kit
17	WASHER 3/8" x 3/4" x 184 SS	10	See Pump Fasteners Kit See Motor Fasteners Kit
	PUMP FASTENERS KIT	1	801280
18	PUMP CASING	1	See Pump Casing Assembly
	PUMP CASING ASSEMBLY		C176-71P
19	BARREL UNION KIT (INCLUDES 19a, 19b & 19c) x2	1	801245
19a	COLLAR UNION 2" SLIP	2	
19b	COLLAR UNION 2"	2	See Barrel Union Kit
19c	ORING-Collar Union	2	
20	BASE	1	
21	SCREW 5/16-14" x 1"	2	See Pump Base Kit
22	MOTOR PAD	1	
	BASE KIT (INCLUDES 19, 20 & 21)	1	801281



IMPORTANT

Please attach your sales invoice/docket here as proof of purchase should warranty service be required.

Please do not return Warranty Form to Pentair Australia - please retain for your records.

Purchased From

Purchase Date..... Serial No..... Model No.....



Head Office

Pentair AU/NZ: 1-21 Monash Drive,
Dandenong South, Vic 3175

Australia

National Customer Service: Phone: 1300 137 344
Fax: 1800 006 688
National Dealer Locator: Phone: 1800 664 266
Email: au.sales@pentair.com
Web: www.pentair.com.au

New Zealand

National Customer Service: Phone: 0800 654 112
Fax: 0800 806 642
National Dealer Locator: Phone: 0800 664 269
Email: nz.sales@pentair.com
Web: www.pentair.co.nz

International Australia/New Zealand

Phone: +61 3 9709 5800
Fax: +61 3 9709 5888

© Information contained here-in remains the property of Pentair Water Pty Ltd. Any reproduction, display, publication, modification or distribution is strictly prohibited without the prior written permission of Pentair Water Pty Ltd.

Disclaimer: Every endeavour has been made to publish the correct details in this data sheet. No responsibility will be taken for errors, omissions or changes in product specifications. Pentair Water reserves the right to change specifications